

Doc. Number :

- Tentative Specification
- Preliminary Specification
- Approval Specification

MODEL NO.: G104AGE
SUFFIX: L02

Customer:	
APPROVED BY	SIGNATURE
<u>Name / Title</u>	_____
Note	

Please return 1 copy for your confirmation with your signature and comments.	

Approved By	Checked By	Prepared By

- CONTENTS -

REVISION HISTORY	-----	3
1. GENERAL DESCRIPTION	-----	4
1.1 OVERVIEW		
1.2 FEATURES		
1.3 APPLICATION		
1.4 GENERAL SPECIFICATIONS		
1.5 MECHANICAL SPECIFICATIONS		
2. ABSOLUTE MAXIMUM RATINGS	-----	6
2.1 ABSOLUTE RATINGS OF ENVIRONMENT		
2.2 ELECTRICAL ABSOLUTE RATINGS		
2.2.1 TFT LCD MODULE		
2.2.2 BACKLIGHT UNIT		
3. ELECTRICAL CHARACTERISTICS	-----	8
3.1 TFT LCD MODULE		
3.2 BACKLIGHT UNIT		
4. BLOCK DIAGRAM	-----	10
4.1 TFT LCD MODULE		
5. INPUT TERMINAL PIN ASSIGNMENT	-----	11
5.1 TFT LCD MODULE		
5.2 BACKLIGHT UNIT		
5.3 COLOR DATA INPUT ASSIGNMENT		
6. INTERFACE TIMING	-----	14
6.1 INPUT SIGNAL TIMING SPECIFICATIONS		
6.2 POWER ON/OFF SEQUENCE		
6.3 THE INPUT DATA FORMAT		
6.4 SCANNING DIRECTION		
7. OPTICAL CHARACTERISTICS	-----	18
7.1 TEST CONDITIONS		
7.2 OPTICAL SPECIFICATIONS		
8. RELIABILITY TEST CRITERIA	-----	22
9. PACKAGING	-----	23
9.1 PACKING SPECIFICATIONS		
9.2 PACKING METHOD		
10. DEFINITION OF LABELS	-----	24
11. PRECAUTIONS	-----	25
11.1 ASSEMBLY AND HANDLING PRECAUTIONS		
11.2 SAFETY PRECAUTIONS		
12. MECHANICAL CHARACTERISTICS	-----	26

REVISION HISTORY

Version	Date	Section	Description
0.0	Nov 7, 2011	All	G104AGE-L02 Tentative Spec. was first issued

1. GENERAL DESCRIPTION

1.1 OVERVIEW

The G104S1-L01 model is a 10.4" TFT-LCD module with a white LED Backlight Unit and a 20-pin 1ch-LVDS interface. This module supports 800 x 600 SVGA mode and displays 262k/16.2M colors. The converter for the Backlight Unit is built in.

1.2 FEATURES

- Wide viewing angle
- High contrast ratio
- Fast response time
- SVGA (800 x 600 pixels) resolution
- Wide operating temperature
- DE (Data Enable) mode
- LVDS (Low Voltage Differential Signaling) interface
- Reversible scan direction
- RoHS Compliance

1.3 APPLICATION

- TFT LCD Monitor
- Industrial Application
- Amusement

1.4 GENERAL SPECIFICATIONS

Item	Specification	Unit	Note
Diagonal Size	10.4	inch	(1)
Active Area	211.2(H) x 158.4(V)	mm	
Bezel Opening Area	214.8 x 162.7	mm	
Driver Element	a-si TFT active matrix	-	-
Pixel Number	800 x R.G.B. x 600	pixel	-
Pixel Pitch	0.264(H) x 0.264(V)	mm	-
Pixel Arrangement	RGB vertical stripe	-	-
Display Colors	262k/16.2M	color	-
Transmissive Mode	Normally white	-	-
Surface Treatment	Hard coating (3H), AG	-	-
Module Power Consumption	(4.8)	W	Typ.

1.5 MECHANICAL SPECIFICATIONS

Item		Min.	Typ.	Max.	Unit	Note
Module Size	Horizontal (H)	242.5	243	243.5	mm	(1)
	Vertical (V)	183.5	184	184.5	mm	
	Depth (D)	-	(8.0)	(8.5)	mm	
Weight		-	(355)	-	g	-
I/F connector mounting position		The mounting inclination of the connector makes the screen center within $\pm 0.5\text{mm}$ as the horizontal.			-	(2)

Note (1) Please refer to the attached drawings for more information of front and back outline dimensions.

(2) Connector mounting position

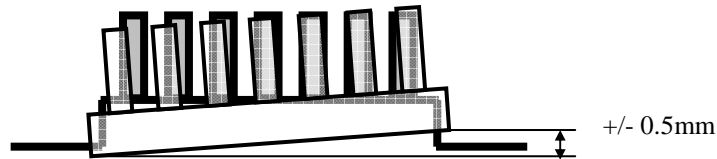

2. ABSOLUTE MAXIMUM RATINGS

2.1 ABSOLUTE RATINGS OF ENVIRONMENT

Item	Symbol	Value		Unit	Note
		Min.	Max.		
Operating Ambient Temperature	T _{OP}	(-30)	(+85)	°C	
Storage Temperature	T _{ST}	(-30)	(+85)	°C	

Note (1) Temperature and relative humidity range is shown in the figure below.

- (2) 90 %RH Max. (Ta ≤ 40 °C).
- (3) Wet-bulb temperature should be 39 °C Max. (Ta > 40 °C).
- (4) No condensation.

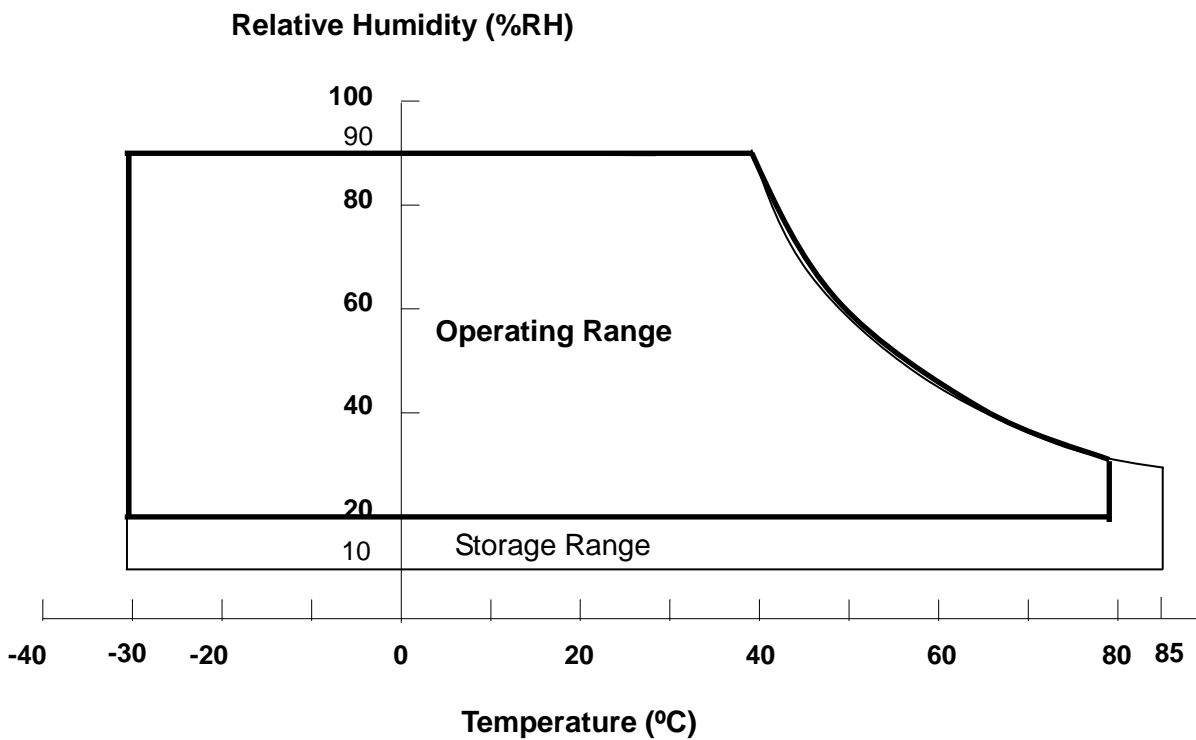

2.2 ELECTRICAL ABSOLUTE RATINGS

2.2.1 TFT LCD MODULE

Item	Symbol	Value		Unit	Note
		Min.	Max.		
Power Supply Voltage	VCC	(-0.3)	(7)	V	(1)

2.2.2 BACKLIGHT UNIT

Item	Symbol	Value		Unit	Note
		Min.	Max.		
Converter Voltage	V_i	(-0.3)	(18)	V	(1), (2)
Enable Voltage	EN	---	(5.5)	V	
Backlight Adjust	ADJ	---	(5.5)	V	

Note (1) Permanent damage to the device may occur if maximum values are exceeded. Function operation should be restricted to the conditions described under Normal Operating Conditions.

Note (2) Specified values are for lamp (Refer to 3.2 for further information).

3. ELECTRICAL CHARACTERISTICS

3.1 TFT LCD MODULE

Ta = 25 ± 2 °C

Parameter	Symbol	Value			Unit	Note
		Min.	Typ.	Max.		
Power Supply Voltage	V _{CC}	(3.0)	3.3	(3.6)	V	(1) at V _{CC} =3.3V
Rush Current	I _{RUSH}	-	-	(1.5)	A	(2)
Power Supply Current	White	-	(410)	(490)	mA	(3)a, at V _{CC} =3.3V
	Black	-	(540)	(650)	mA	(3)b, at V _{CC} =3.3V
Power Consumption	P _L	-	(2.0)	-	W	
LVDS differential input voltage	VID	(100)	-	(600)	mV	-
LVDS common input voltage	V _{ICM}	(0.7)	-	(1.6)	V	-

Note (1) The assembly should be always operated within above ranges.

Note (2) Measurement Conditions:

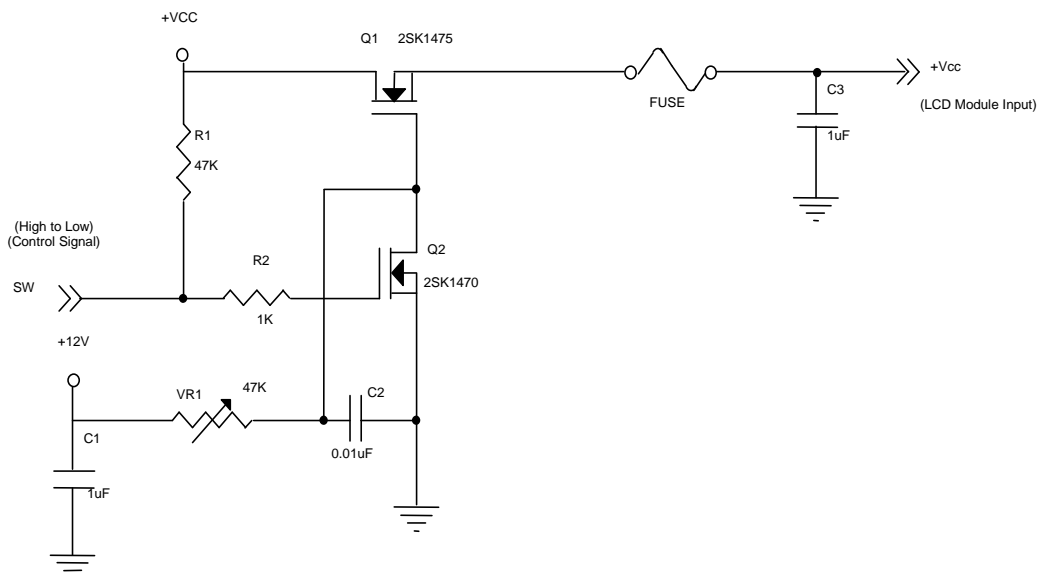

Vcc rising time is 470μs

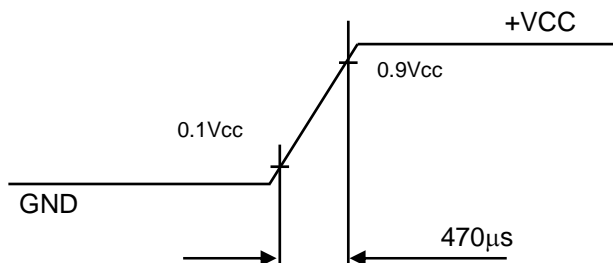

Note (3) The specified power supply current is under the conditions at $V_{cc} = 3.3V$, $T_a = 25 \pm 2 \text{ }^\circ\text{C}$, $f_v = 60$ Hz, whereas a power dissipation check pattern below is displayed.

a. White Pattern



Active Area

b. Black Pattern

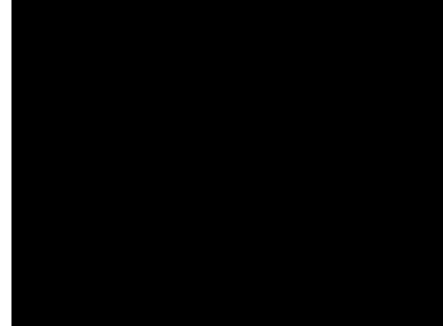

Active Area

3.2 BACKLIGHT UNIT

$T_a = 25 \pm 2 \text{ }^\circ\text{C}$

Parameter	Symbol	Value			Unit	Note	
		Min.	Typ.	Max.			
Converter Power Supply Voltage	V_i	(7)	12.0	(17)	V		
Converter Power Supply Current	I_i	-	(0.25)	(0.3)	A	@ $V_i = 12V$ (Duty 100%)	
LED Power Consumption	P_{LED}	-	(3.0)	(3.6)	W	@ $V_i = 12V$ (Duty 100%)	
EN Control Level	Backlight on	-	(2.0)	3.3	(5.0)	V	
	Backlight off	-	(0)	---	(0.8)	V	
PWM Control Level	PWM High Level	-	(2.0)	3.3	(5.0)	V	
	PWM Low Level	-	(0)	-	(0.15)	V	
PWM Control Duty Ratio	-	(2)	-	(100)	%	Note(3)	
PWM Control Frequency	f_{PWM}	(190)	(200)	(20000)	Hz	Note(3)	
LED Life Time	L_L	(30,000)	-	-	Hrs	(2)	

Note (1) LED current is measured by utilizing a high frequency current meter as shown below:

Note (2) The lifetime of LED is defined as the time when it continues to operate under the conditions at $T_a = 25 \pm 2 \text{ }^\circ\text{C}$ and Duty 100% until the brightness becomes $\leq 50\%$ of its original value. Operating LED under high temperature environment will reduce life time and lead to color shift.

Note (3) At 190 ~1KHz PWM control frequency, duty ratio range is restricted from 2% to 100%.
1K ~20KHz PWM control frequency, minimum duty on-time $\geq 20 \text{ } \mu\text{s}$

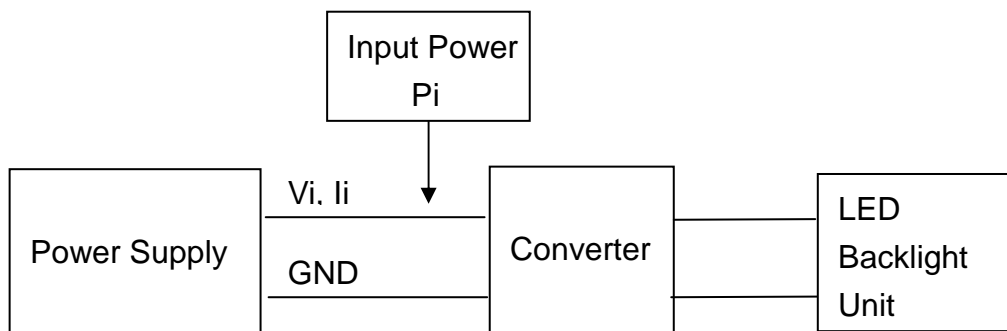

4. BLOCK DIAGRAM

4.1 TFT LCD MODULE

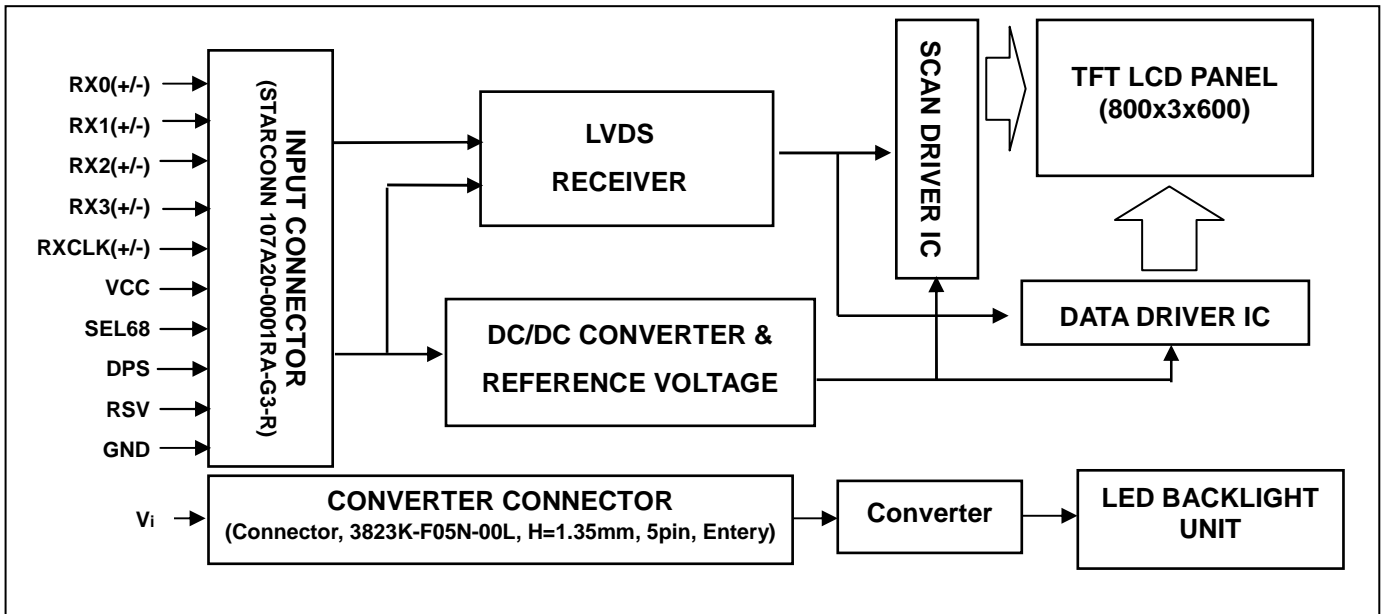

5. INPUT TERMINAL PIN ASSIGNMENT

5.1 TFT LCD MODULE

Pin	Name	Description	Remark
1	VCC	Power supply	
2	VCC	Power supply	
3	GND	Ground	
4	DPS	Reverse Scan Function [High : Enable , Low : Disable]	Note (3)
5	RX0-	Differential Data Input, CH0 (Negative)	
6	RX0+	Differential Data Input, CH0 (Positive)	
7	GND	Ground	
8	RX1-	Differential Data Input, CH1 (Negative)	
9	RX1+	Differential Data Input , CH1 (Positive)	
10	GND	Ground	
11	RX2-	Differential Data Input , CH2 (Negative)	
12	RX2+	Differential Data Input , CH2 (Positive)	
13	GND	Ground	
14	RXC-	Differential Clock Input (Negative)	
15	RXC+	Differential Clock Input (Positive)	
16	GND	Ground	
17	RX3-	Differential Data Input, CH3 (Negative)	
18	RX3+	Differential Data Input, CH3 (Positive)	
19	RSV	Reserved for internal test. Please treat it as NC.	
20	SEL68	LVDS 6/8 bit select function control, Low or NC → 6 bit Input Mode High → 8bit Input Mode	Note (3)

Note (1) Connector Part No.: STARCONN 107A20-0022RA-G3-R or equivalent.

Note (2) User's connector Part No.: STARCONN 093A20-010010-T4, HRS DF19G-20S-1C(05), STM P24013P20 or equivalent.

Note (3) "Low" stands for 0V. "High" stands for 3.3V. "NC" stands for "No Connected".

5.2 BACKLIGHT UNIT(Converter connector pin)

Pin	Symbol	Description	Remark
1	V_i	Converter input voltage	12V
2	V_{GND}	Converter ground	Ground
3	EN	Enable pin	3.3V
4	ADJ	Backlight Adjust	PWM Dimming (Hi: 3.3V _{DC} , Lo: 0V _{DC})
5	NC	Not Connect	Ground

Note (1) Connector Part No.: 3823K-F05N-00L (Entery) or equivalent.

Note (2) User's connector Part No.: H208K-P05N-02B (Entery) or equivalent.

5.3 COLOR DATA INPUT ASSIGNMENT

The brightness of each primary color (red, green and blue) is based on the 6-bit gray scale data input for the color. The higher the binary input, the brighter the color. The table below provides the assignment of color versus data input.

Color		Data Signal																	
		Red						Green						Blue					
		R5	R4	R3	R2	R1	R0	G5	G4	G3	G2	G1	G0	B5	B4	B3	B2	B1	B0
Basic Colors	Black	0	0	0	0	0	0	0	0	0	0	0	0	0	0	0	0	0	0
	Red	1	1	1	1	1	1	0	0	0	0	0	0	0	0	0	0	0	0
	Green	0	0	0	0	0	0	1	1	1	1	1	1	0	0	0	0	0	0
	Blue	0	0	0	0	0	0	0	0	0	0	0	0	1	1	1	1	1	1
	Cyan	0	0	0	0	0	0	1	1	1	1	1	1	1	1	1	1	1	1
	Magenta	1	1	1	1	1	1	0	0	0	0	0	0	1	1	1	1	1	1
	Yellow	1	1	1	1	1	1	1	1	1	1	1	1	0	0	0	0	0	0
	White	1	1	1	1	1	1	1	1	1	1	1	1	1	1	1	1	1	1
Gray Scale Of Red	Red(0)/Dark	0	0	0	0	0	0	0	0	0	0	0	0	0	0	0	0	0	0
	Red(1)	0	0	0	0	0	1	0	0	0	0	0	0	0	0	0	0	0	0
	Red(2)	0	0	0	0	1	0	0	0	0	0	0	0	0	0	0	0	0	0
	:	:	:	:	:	:	:	:	:	:	:	:	:	:	:	:	:	:	:
	:	:	:	:	:	:	:	:	:	:	:	:	:	:	:	:	:	:	:
	:	:	:	:	:	:	:	:	:	:	:	:	:	:	:	:	:	:	:
	Red(61)	1	1	1	1	0	1	0	0	0	0	0	0	0	0	0	0	0	0
	Red(62)	1	1	1	1	1	0	0	0	0	0	0	0	0	0	0	0	0	0
Red(63)	1	1	1	1	1	1	0	0	0	0	0	0	0	0	0	0	0	0	
Gray Scale Of Green	Green(0)/Dark	0	0	0	0	0	0	0	0	0	0	0	0	0	0	0	0	0	0
	Green(1)	0	0	0	0	0	0	0	0	0	0	0	1	0	0	0	0	0	0
	Green(2)	0	0	0	0	0	0	0	0	0	0	1	0	0	0	0	0	0	0
	:	:	:	:	:	:	:	:	:	:	:	:	:	:	:	:	:	:	:
	:	:	:	:	:	:	:	:	:	:	:	:	:	:	:	:	:	:	:
	:	:	:	:	:	:	:	:	:	:	:	:	:	:	:	:	:	:	:
	Green(61)	0	0	0	0	0	0	1	1	1	1	0	1	0	0	0	0	0	0
	Green(62)	0	0	0	0	0	0	1	1	1	1	1	0	0	0	0	0	0	0
Green(63)	0	0	0	0	0	0	1	1	1	1	1	1	0	0	0	0	0	0	
Gray Scale Of Blue	Blue(0)/Dark	0	0	0	0	0	0	0	0	0	0	0	0	0	0	0	0	0	0
	Blue(1)	0	0	0	0	0	0	0	0	0	0	0	0	0	0	0	0	0	1
	Blue(2)	0	0	0	0	0	0	0	0	0	0	0	0	0	0	0	0	1	0
	:	:	:	:	:	:	:	:	:	:	:	:	:	:	:	:	:	:	:
	:	:	:	:	:	:	:	:	:	:	:	:	:	:	:	:	:	:	:
	:	:	:	:	:	:	:	:	:	:	:	:	:	:	:	:	:	:	:
	Blue(61)	0	0	0	0	0	0	0	0	0	0	0	0	1	1	1	1	0	1
	Blue(62)	0	0	0	0	0	0	0	0	0	0	0	0	1	1	1	1	1	0
Blue(63)	0	0	0	0	0	0	0	0	0	0	0	0	1	1	1	1	1	1	

Note (1) 0: Low Level Voltage, 1: High Level Voltage

The brightness of each primary color (red, green and blue) is based on the 8-bit gray scale data input for the color. The higher the binary input, the brighter the color. The table below provides the assignment of color versus data input.

Color		Data Signal																						
		Red								Green								Blue						
		R7	R6	R5	R4	R3	R2	R1	R0	G7	G6	G5	G4	G3	G2	G1	G0	B7	B6	B5	B4	B3	B2	B1
Basic Colors	Black	0	0	0	0	0	0	0	0	0	0	0	0	0	0	0	0	0	0	0	0	0	0	0
	Red	1	1	1	1	1	1	1	1	0	0	0	0	0	0	0	0	0	0	0	0	0	0	0
	Green	0	0	0	0	0	0	0	0	1	1	1	1	1	1	1	1	0	0	0	0	0	0	0
	Blue	0	0	0	0	0	0	0	0	0	0	0	0	0	0	0	0	1	1	1	1	1	1	1
	Cyan	0	0	0	0	0	0	0	0	1	1	1	1	1	1	1	1	1	1	1	1	1	1	1
	Magenta	1	1	1	1	1	1	1	1	0	0	0	0	0	0	0	0	1	1	1	1	1	1	1
	Yellow	1	1	1	1	1	1	1	1	1	1	1	1	1	1	1	1	0	0	0	0	0	0	0
	White	1	1	1	1	1	1	1	1	1	1	1	1	1	1	1	1	1	1	1	1	1	1	1
Gray Scale Of Red	Red(0) / Dark	0	0	0	0	0	0	0	0	0	0	0	0	0	0	0	0	0	0	0	0	0	0	
	Red(1)	0	0	0	0	0	0	0	1	0	0	0	0	0	0	0	0	0	0	0	0	0	0	
	Red(2)	0	0	0	0	0	0	1	0	0	0	0	0	0	0	0	0	0	0	0	0	0	0	
	:	:	:	:	:	:	:	:	:	:	:	:	:	:	:	:	:	:	:	:	:	:	:	
	:	:	:	:	:	:	:	:	:	:	:	:	:	:	:	:	:	:	:	:	:	:	:	
	Red(253)	1	1	1	1	1	1	0	1	0	0	0	0	0	0	0	0	0	0	0	0	0	0	
	Red(254)	1	1	1	1	1	1	1	0	0	0	0	0	0	0	0	0	0	0	0	0	0	0	
	Red(255)	1	1	1	1	1	1	1	1	0	0	0	0	0	0	0	0	0	0	0	0	0	0	
Gray Scale Of Green	Green(0)/ Dark	0	0	0	0	0	0	0	0	0	0	0	0	0	0	0	0	0	0	0	0	0	0	
	Green(1)	0	0	0	0	0	0	0	0	0	0	0	0	0	0	1	0	0	0	0	0	0	0	
	Green(2)	0	0	0	0	0	0	0	0	0	0	0	0	0	1	0	0	0	0	0	0	0	0	
	:	:	:	:	:	:	:	:	:	:	:	:	:	:	:	:	:	:	:	:	:	:	:	
	:	:	:	:	:	:	:	:	:	:	:	:	:	:	:	:	:	:	:	:	:	:	:	
	Green(253)	0	0	0	0	0	0	0	0	1	1	1	1	1	1	0	1	0	0	0	0	0	0	
	Green(254)	0	0	0	0	0	0	0	0	1	1	1	1	1	1	1	0	0	0	0	0	0	0	
	Green(255)	0	0	0	0	0	0	0	0	1	1	1	1	1	1	1	1	0	0	0	0	0	0	
Gray Scale Of Blue	Blue(0) / Dark	0	0	0	0	0	0	0	0	0	0	0	0	0	0	0	0	0	0	0	0	0	0	
	Blue(1)	0	0	0	0	0	0	0	0	0	0	0	0	0	0	0	0	0	0	0	0	0	1	
	Blue(2)	0	0	0	0	0	0	0	0	0	0	0	0	0	0	0	0	0	0	0	0	0	1	
	:	:	:	:	:	:	:	:	:	:	:	:	:	:	:	:	:	:	:	:	:	:	:	
	:	:	:	:	:	:	:	:	:	:	:	:	:	:	:	:	:	:	:	:	:	:	:	
	Blue(253)	0	0	0	0	0	0	0	0	0	0	0	0	0	0	0	1	1	1	1	1	1	0	
	Blue(254)	0	0	0	0	0	0	0	0	0	0	0	0	0	0	0	1	1	1	1	1	1	1	
	Blue(255)	0	0	0	0	0	0	0	0	0	0	0	0	0	0	0	1	1	1	1	1	1	1	

Note (1) 0: Low Level Voltage, 1: High Level Voltage

6. INTERFACE TIMING

6.1 INPUT SIGNAL TIMING SPECIFICATIONS

The input signal timing specifications are shown as the following table and timing diagram.

Signal	Item	Symbol	Min.	Typ.	Max.	Unit	Note
DCLK	Frequency	Fc	(30)	(40)	(50)	MHz	
Vertical Active Display Term	Total	Tv	(608)	(628)	(1024)	Th	Tv=Tvd+Tvb
	Display	Tvd	-	(600)	-	Th	-
	Blank	Tvb	(8)	(28)	(424)	Th	-
Horizontal Active Display Term	Total	Th	(960)	(1056)	(1060)	Tc	Th=Thd+Thb
	Display	Thd	-	(800)	-	Tc	-
	Blank	Thb	(160)	(256)	(260)	Tc	-

Note (1) Since this assembly is operated in DE only mode, Hsync and Vsync input signals should be set to low logic level. Otherwise, this assembly would operate abnormally.

(2) Frame rate is 60Hz

INPUT SIGNAL TIMING DIAGRAM

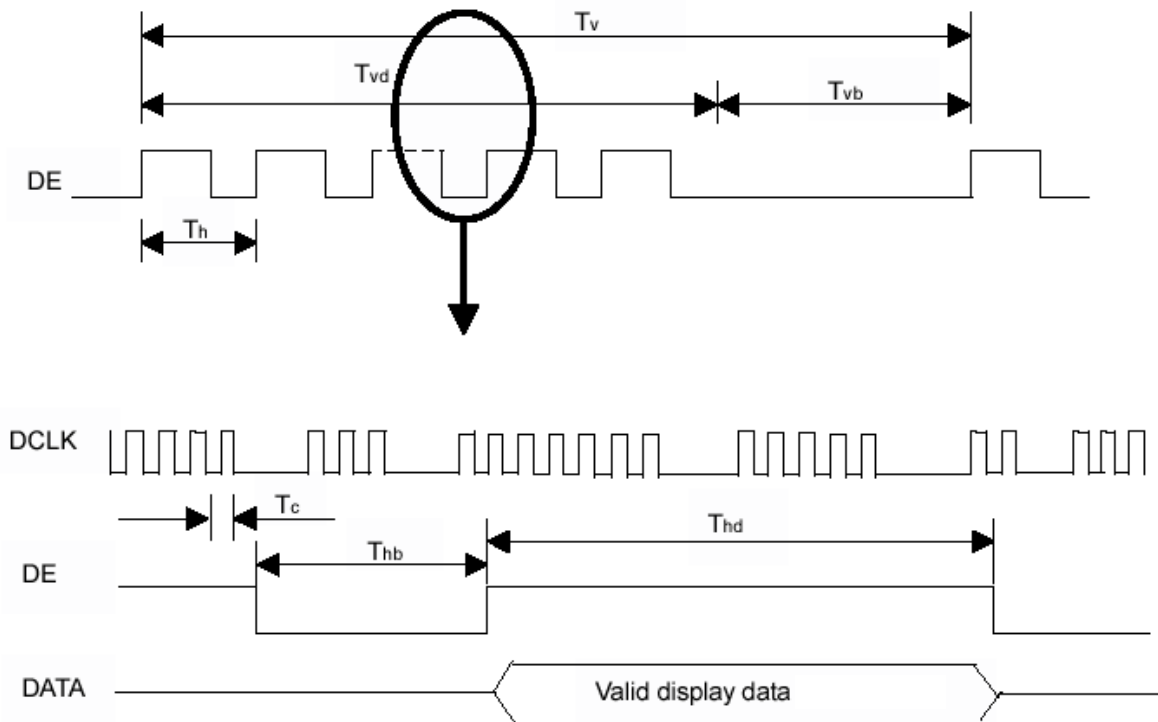

6.2 POWER ON/OFF SEQUENCE

To prevent a latch-up or DC operation of LCD assembly, the power on/off sequence should be as the diagram below.

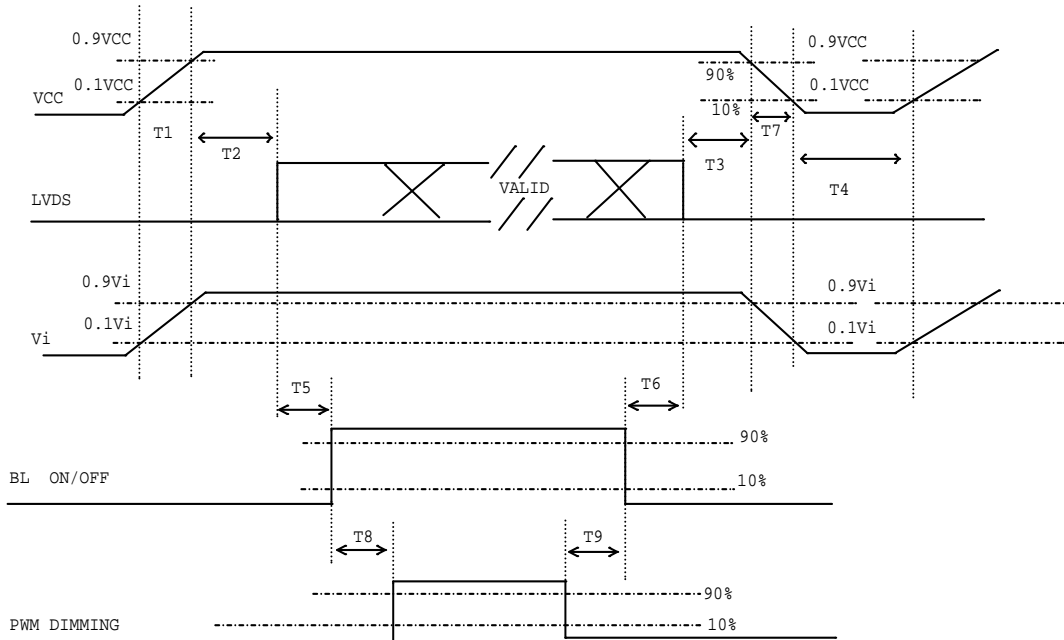

Power ON/OFF sequence

Note (1) Please avoid floating state of interface signal at invalid period.

Note (2) When the interface signal is invalid, be sure to pull down the power supply of LCD VCC to 0 V.

Note (3) The Backlight converter power must be turned on after the power supply for the logic and the interface signal is valid. The Backlight converter power must be turned off before the power supply for the logic and the interface signal is invalid.

Parameter	Value			Units
	Min	Typ	Max	
T1	(0.5)	-	(10)	ms
T2	(0)	-	(50)	ms
T3	(0)	-	(50)	ms
T4	(500)	-	-	ms
T5	(200)	-	-	ms
T6	(200)	-	-	ms
T7	(5)	-	(300)	ms
T8	(10)	-	-	ms
T9	(10)	-	-	ms

6.3 The Input Data Format

SEL68 = "Low" or "NC" for 6 bits LVDS Input

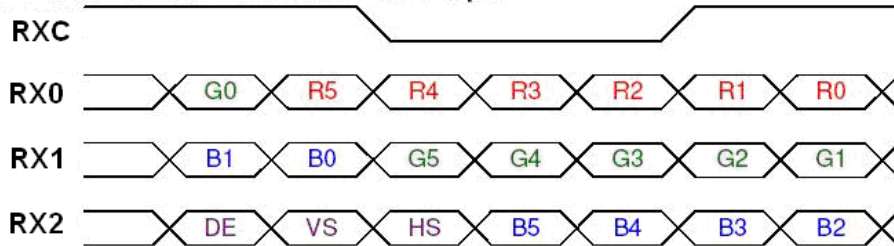

SEL68 = "High" for 8 bits LVDS Input

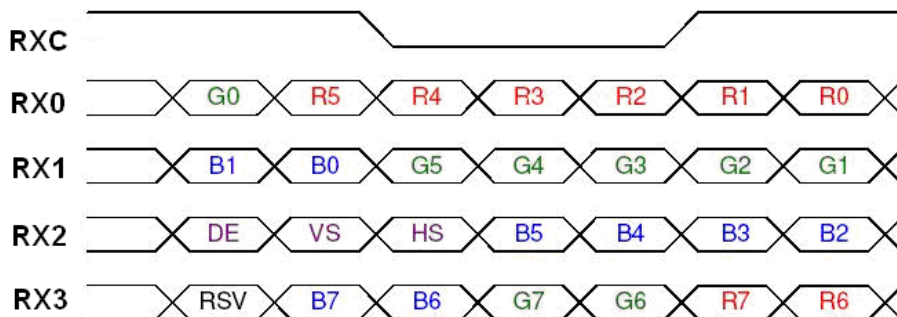

Note (1) R/G/B data 7: MSB, R/G/B data 0: LSB

Note (2) Please follow PSWG

Signal Name	Description	Remark
R7	Red Data 7 (MSB)	Red-pixel Data Each red pixel's brightness data consists of these 8 bits pixel data.
R6	Red Data 6	
R5	Red Data 5	
R4	Red Data 4	
R3	Red Data 3	
R2	Red Data 2	
R1	Red Data 1	
R0	Red Data 0 (LSB)	
G7	Green Data 7 (MSB)	Green-pixel Data Each green pixel's brightness data consists of these 8 bits pixel data.
G6	GreenData 6	
G5	GreenData 5	
G4	GreenData 4	
G3	GreenData 3	
G2	GreenData 2	
G1	GreenData 1	
G0	GreenData 0 (LSB)	
B7	Blue Data 7 (MSB)	Blue-pixel Data Each blue pixel's brightness data consists of these 8 bits pixel data.
B6	Blue Data 6	
B5	Blue Data 5	
B4	Blue Data 4	
B3	Blue Data 3	
B2	Blue Data 2	
B1	Blue Data 1	
B0	Blue Data 0 (LSB)	
RXCLKIN+	LVDS Clock Input	
RXCLKIN-		
DE	Display Enable	
VS	Vertical Sync	
HS	Horizontal Sync	

Note (3) Output signals from any system shall be low or Hi-Z state when VCC is off.

6.4 Scanning Direction

The following figures show the image see from the front view. The arrow indicates the direction of scan.

Fig.1 Normal Scan



Fig.2 Reverse Scan



Fig. 1 Normal scan (pin 4, DPS = Low or NC)

Fig. 2 Reverse scan (pin 4, DPS = High)

7. OPTICAL CHARACTERISTICS

7.1 TEST CONDITIONS

Item	Symbol	Value	Unit
Ambient Temperature	Ta	25±2	°C
Ambient Humidity	Ha	50±10	%RH
Supply Voltage	V _{CC}	3.3	V
Input Signal	According to typical value in "3. ELECTRICAL CHARACTERISTICS"		
Converter Voltage	V _{in}	12	V
Converter Duty		100%	

7.2 OPTICAL SPECIFICATIONS

The relative measurement methods of optical characteristics are shown in 7.2. The following items should be measured under the test conditions described in 7.1 and stable environment shown in Note (5).

Item		Symbol	Condition	Min.	Typ.	Max.	Unit	Note					
Color Chromaticity	Red	Rx	$\theta_x=0^\circ, \theta_y=0^\circ$ CS-1000	Typ - 0.05	(0.609)	Typ + 0.05	-	(1), (5)					
		Ry			(0.339)		-						
	Green	Gx			(0.333)		-						
		Gy			(0.590)		-						
	Blue	Bx			(0.154)		-						
		By			(0.146)		-						
	White	Wx			(0.313)		-						
		Wy			(0.329)		-						
	Center Luminance of White				L _C				(300)	400	-	-	(4), (5)
	Contrast Ratio				CR				(500)	(700)	-	-	(2), (5)
Response Time		T _R	$\theta_x=0^\circ, \theta_y=0^\circ$	-	(5)	(10)	ms	(3)					
		T _F		-	(11)	(16)	ms						
White Variation		δW	$\theta_x=0^\circ, \theta_y=0^\circ$	-	(1.25)	(1.4)	-	(5), (6)					
Viewing Angle	Horizontal	θ _{x+}	CR≥10	(70)	(80)	-	Deg.	(1), (5)					
		θ _{x-}		(70)	(80)	-							
	Vertical	θ _{y+}		(60)	(70)	-							
		θ _{y-}		(60)	(70)	-							

Note (1) Definition of Viewing Angle (θ_x, θ_y):

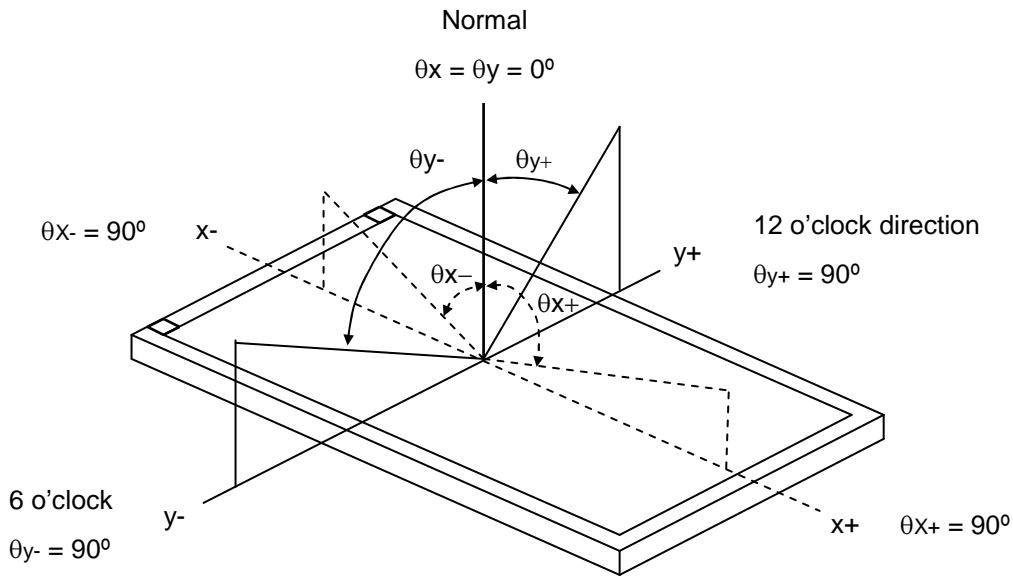

Note (2) Definition of Contrast Ratio (CR):

The contrast ratio can be calculated by the following expression.

$$\text{Contrast Ratio (CR)} = L_{63} / L_0$$

L63: Luminance of gray level 63

L 0: Luminance of gray level 0

$$\text{CR} = \text{CR} (5)$$

CR (X) is corresponding to the Contrast Ratio of the point X at Figure in Note (6).

Note (3) Definition of Response Time (T_R, T_F) and measurement method:

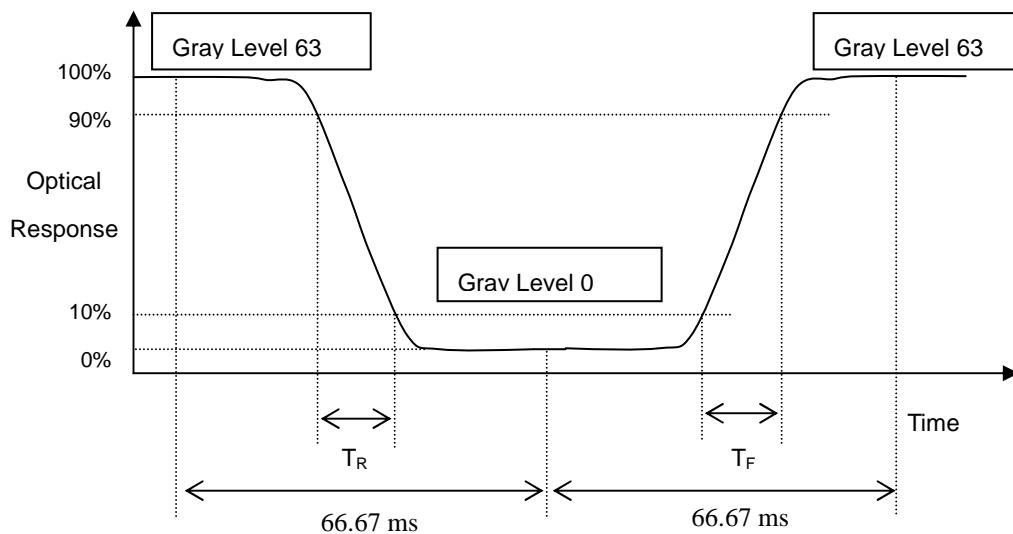

Note (4) Definition of Luminance of White (L_C):

Measure the luminance of gray level 63 at center point

$$L_C = L(5)$$

$L(x)$ is corresponding to the luminance of the point X at Figure in Note (6).

Note (5) Measurement Setup:

The LCD module should be stabilized at given temperature for 20 minutes to avoid abrupt temperature change during measuring. In order to stabilize the luminance, the measurement should be executed after lighting Backlight for 20 minutes in a windless room.

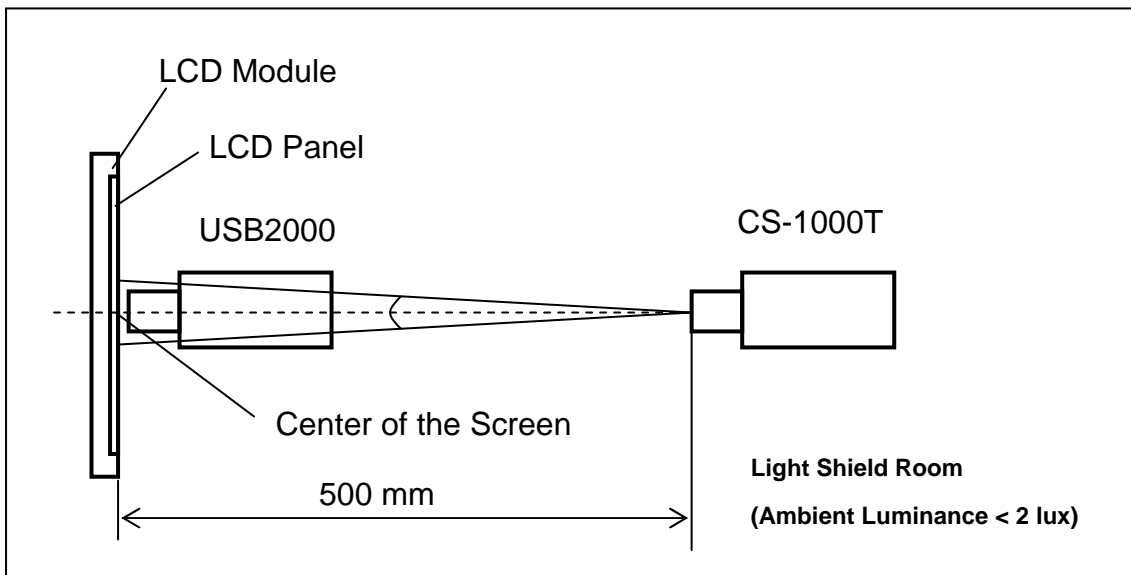

Note (6) Definition of White Variation (δW):

Measure the luminance of gray level 63 at 5 points

$$\delta W = \frac{\text{Maximum [L (1), L (2), L (3), L (4), L (5)]}}{\text{Minimum [L (1), L (2), L (3), L (4), L (5)]}}$$

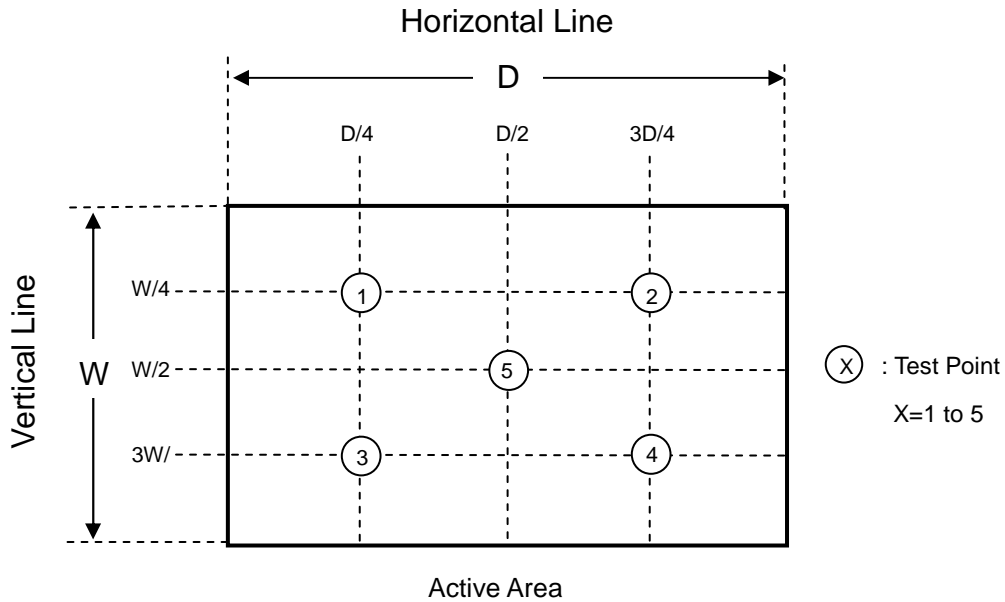

8. RELIABILITY TEST CRITERIA

Test Item	Test Condition	Note
High Temperature Storage Test	(85°C, 240 hours)	(1)(2)
Low Temperature Storage Test	(-30°C, 240 hours)	
Thermal Shock Storage Test	(-30°C, 0.5hour←→85°C, 0.5hour; 1hour/cycle,100cycles)	
High Temperature Operation Test	(85°C, 240 hours)	
Low Temperature Operation Test	(-30°C, 240 hours)	
High Temperature & High Humidity Operation Test	(60°C, 90%RH, 240hours)	
Shock (Non-Operating)	(50G, 11ms, half sine wave, 1 time for ± X, ± Y, ± Z direction)	(3)
Vibration (Non-Operating)	(1.5G, 10 ~ 300 Hz, 10min/cycle, 3 cycles each X, Y, Z)	(3)

Note (1) There should be no condensation on the surface of panel during test.

Note (2) Temperature of panel display surface area should be 80 °C Max.

Note (3) At testing Vibration and Shock, the fixture in holding the module has to be hard and rigid enough so that the module would not be twisted or bent by the fixture.

Note (4) In the standard conditions, there is no function failure issue occurred. All the cosmetic specifications are judged before reliability test.

9. PACKAGING (TBD)

10. DEFINITION OF LABELS

10.1 CMO MODULE LABEL

The barcode nameplate is pasted on each module as illustration, and its definitions are as following explanation.

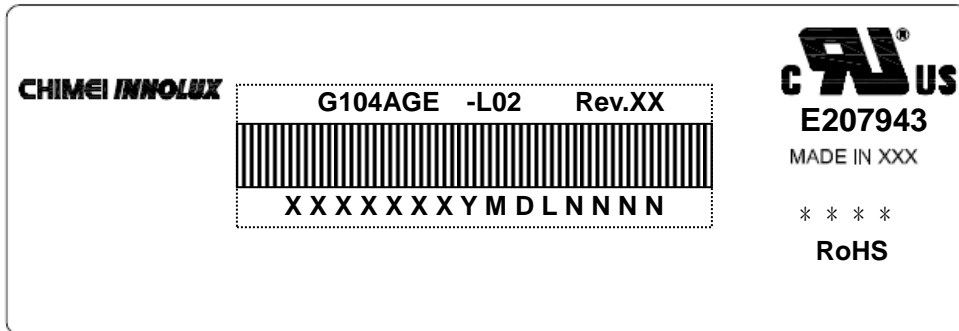

- (a) Model Name: G104AGE -L02
- (b) Revision: Rev. XX, for example: A1, B1, C1, C2 ...etc.
- (c) Serial ID: XXXXXXXXYMDLNNN

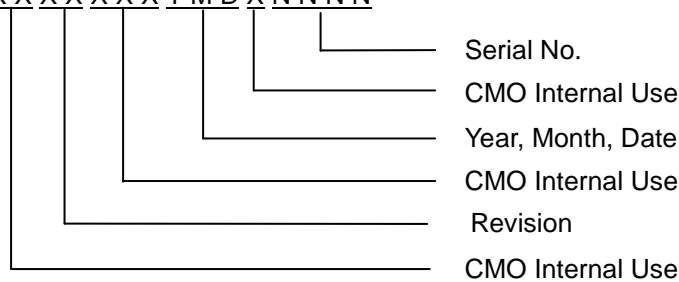

Serial ID includes the information as below:

- (a) Manufactured Date: Year: 1~9, for 2001~2009
 Month: 1~9, A~C, for Jan. ~ Dec.
 Day: 1~9, A~Y, for 1st to 31st, exclude I , O and U
- (b) Revision Code: cover all the change
- (c) Serial No.: Manufacturing sequence of product

11. PRECAUTIONS

11.1 ASSEMBLY AND HANDLING PRECAUTIONS

- (1) Do not apply rough force such as bending or twisting to the module during assembly.
- (2) To assemble or install module into user's system can be only in clean working areas. The dust and oil may cause electrical short or worsen the polarizer.
- (3) It's not permitted to have pressure or impulse on the module because the LCD panel and Backlight will be damaged.
- (4) Always follow the correct power sequence when LCD module is connecting and operating. This can prevent damage to the CMOS LSI chips during latch-up.
- (5) Do not pull the I/F connector in or out while the module is operating.
- (6) Do not disassemble the module.
- (7) Use a soft dry cloth without chemicals for cleaning, because the surface of polarizer is very soft and easily scratched.
- (8) It is dangerous that moisture come into or contacted the LCD module, because moisture may damage LCD module when it is operating.
- (9) High temperature or humidity may reduce the performance of module. Please store LCD module within the specified storage conditions.
- (10) When ambient temperature is lower than 10°C may reduce the display quality. For example, the response time will become slowly.
- (11) Do not keep same pattern in a long period of time. It may cause image sticking on LCD.

11.2 SAFETY PRECAUTIONS

- (1) Do not disassemble the module or insert anything into the Backlight unit.
- (2) If the liquid crystal material leaks from the panel, it should be kept away from the eyes or mouth. In case of contact with hands, skin or clothes, it has to be washed away thoroughly with soap.
- (3) After the module's end of life, it is not harmful in case of normal operation and storage.

12. MECHANICAL CHARACTERISTICS

